

# ULTRA-PORCELAIN™ RF CAPACITOR CATALOG



# PRESIDIO

Catalog 7100

# PRESIDIO COMPONENTS, INC.

## HIGH PERFORMANCE, HIGH RELIABILITY CERAMIC CAPACITORS

### ABOUT PRESIDIO

Presidio Components has been an industry leader in the design and manufacture of ceramic capacitors since 1980. We are dedicated to excellence in manufacturing, process control and customer service. All products are manufactured and tested in our state-of-the-art, 40,000 square foot facility in San Diego, California, allowing for immediate response to your business needs. We have numerous patents, and hundreds of years of combined engineering experience. We can formulate the right product for your application.

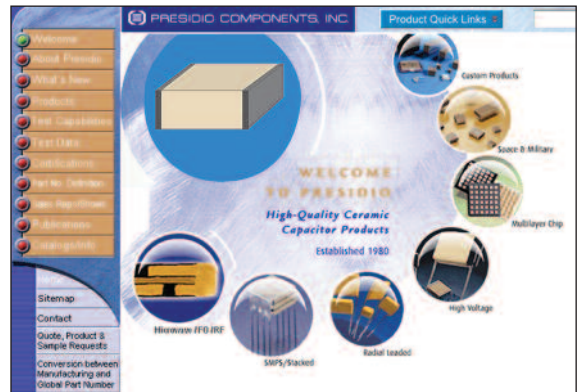

For more information about Presidio's products visit our website: [www.presidiocomponents.com](http://www.presidiocomponents.com)

### TESTING & RELIABILITY

Presidio Components was initially qualified to Mil-PRF-55681 in 1984. Since then we have upgraded our processing line to obtain the highest established reliability of 'S' level. We are also qualified on two additional space level applications, Mil-PRF-123 and Mil-PRF-49470 'T' level. Presidio Components is also proud to be the first QPL supplier to Mil-PRF-49467, the high voltage ceramic capacitor specification. All QPL testing per Mil-STD-202 is done on site at our DSCC approved test lab. For a list of environmental test capabilities, consult the factory.

### CUSTOMER SERVICE

At Presidio Components we work hard to build positive, long-term relationships with our customers and we will go the extra distance to ensure customer satisfaction. If you cannot find a part anywhere else, call Presidio Components. With more than 70 million parts in inventory, we have many commercial and military parts in stock. Our patented ceramic capacitors are typically used in low noise, filter, tuning, broadband DC blocking, and RF bypass applications.

Presidio Components, Inc.  
San Diego, California



# SURFACE MOUNT VERTICAL ELECTRODE™ CAPACITORS

## PRESIDIO ADVANTAGE

- Ultra Lowest ESL
- Ultra Highest Q
- Ultra Combination of ESR and Q
- Ultra Stable NPO
- Ultra Stable Over Time — No Aging
- Ultra Compliant — Strontium Free
- Vertical Electrodes Built In
- Low Profile

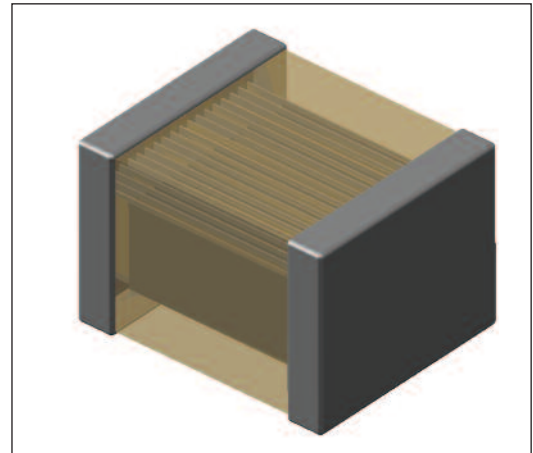

## DIELECTRIC SELECTION:

**Porcelain NPO:** Ultra temperature stable dielectric. Extremely low ESR. For RF power and high Q applications.

**Porcelain P90:** Dielectric increases over temperature (90ppm/C). Extremely low ESR. For temperature compensation.

**Ceramic NPO:** Ultra temperature stable dielectric. Low ESR. Suited for higher capacitance applications.

**Ceramic BX:** Temperature stable X7R dielectric. Suited for highest capacitance value applications.

## TYPICAL APPLICATIONS:

### Filter Capacitors

A filter design requires a specific capacitance value, cF, and at the upper end of the filter response, fF, the effective capacity must not exceed cF by more than a specifies amount of delta C. Once cF is determined, case size, voltage rating and temperature characteristics can be selected.

### DC Block and RF Bypass

The bandwidth over which the insertion loss meets specification is determined by the location of parallel resonances. Minimum insertion loss at the band center is achieved by choosing a capacitor whose lowest series resonance is approximately at this frequency. Low impedance is typically more important than the capacitance value.

### Low Noise Applications

Dissipation loss is the consideration. ESR is very small at the series resonance, very large at the parallel resonance. The neighboring parallel resonances determine the bandwidth.

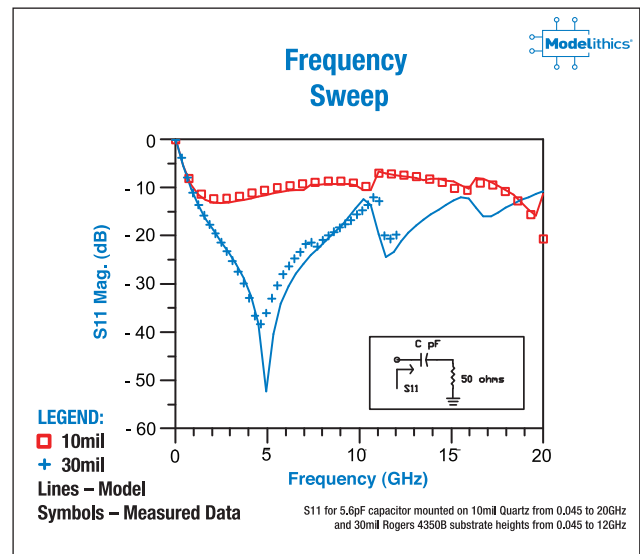

**MVP SERIES — GLOBAL PART NUMBER EXAMPLE (How to Order)**

<b>M</b>	<b>VP</b>	<b>0505</b>	<b>U</b>	<b>101</b>	<b>K</b>	<b>4</b>	<b>T</b>	<b>1</b>	<b>R</b>	<b>—</b>	<b>*</b>
Test Code	VP = Vertical Electrode Product Series	Size	Dielectric	Capacitance	Capacitance Tolerance	Voltage	Termination	Packaging	RoHS Compliant	Hyphen Required	Design-In Code (See Page 15)

**Test Codes, Dielectric Codes and Specifications**

						FIT* 85° C	FIT* 100° C	Mil-PRF-38534E Table C-III	-55681 Similar	-123 Similar	Cust. Spec.		
						<b>M</b>	<b>N</b>	<b>H</b>	<b>K</b>	<b>C</b>	<b>S</b>	<b>D</b>	
						Upgradable to Codes:		H, K	C, S				
<b>TEST CODES:</b>						M		N		C		S	
<b>Upgradable to Codes:</b>						H, K		C, S					
<b>ELECTRICAL SPECIFICATIONS</b>						<b>Test Samples</b>		<b>Test Samples</b>		<b>Test Samples</b>		<b>Test Samples</b>	
Temperature Coefficient of Capacitance, 0 Volt	0 ± 30 ppm/°C	P90 ± 20 ppm/°C	0 ± 30 ppm/°C	± 15%	Para 3.23								
Rated Operating Temperature Range	-55° to +125° C	-55° to +125° C	-55° to +125° C	-55° to +125° C	Para 3.14								
Capacitance up to 1000pF	1 MHz, 1.0 V AC RMS	1 MHz, 1.0 V AC RMS	1 MHz, 1.0 V AC RMS		Para 3.7	100%	100%	100%	100%	100%	100%		
Capacitance >1000pF	1 kHz, 1.0 V AC RMS	1 kHz, 1.0 V AC RMS	1 kHz, 1.0 V AC RMS	1 kHz, 1.0 V AC RMS		100%	100%	100%	100%	100%	100%		
Dissipation Factor, max.	0.05% max.	0.05% max.	0.15% max.	2.5% max.	Para 3.8	100%	100%	100%	100%	100%	100%		
Insulation Resistance @ +25° C at WVDC	1,000,000 MΩ min.	1,000,000 MΩ min.	100,000 MΩ min.	1,000 MΩ Farad	Para 3.9	1% AQL	1% AQL	100%	100%	100%	100%		
Insulation Resistance @ +125° C at WVDC	100,000 MΩ min.	100,000 MΩ min.	10,000 MΩ min.	100 MΩ Farad	Para 3.12					1% AQL	1% AQL		
Dielectric Withstanding Voltage (DWV)	250% of WVDC ≤ 300V 200% of WVDC = 500V	250% of WVDC ≤ 300V 200% of WVDC = 500V	250% of WVDC ≤ 300V 200% of WVDC = 500V	250% of WVDC ≤ 300V 200% of WVDC = 500V		1% AQL	1% AQL	100%	100%	100%	100%		
Aging Effects	None	None	None	2.5% max/decade hr									
<b>VISUAL &amp; MECHANICAL SPECIFICATIONS</b>													
Visual Inspection, Workmanship					Para 3.26	100%	100%	100%	100%	100%	100%		
Solderability (Term. Code T & N Only)					Para 3.13	13	13	13	13	13	13		
Bond Strength (Term. Code P & G Only)	3 grams, 0.001" dia. Au wire	3 grams, 0.001" dia. Au wire	3 grams, 0.001" dia. Au wire	3 grams, 0.001" dia. Au wire	STD-883 Method 2011			10	10	10	10		
Shear Strength (Term. Code P & G Only)					883 Meth. 2019					10	10		
Physical Dimensions	See Page 5	See Page 5	See Page 5	See Page 5						20	20		
<b>ENVIRONMENTAL TESTS, LEVEL I</b>													
Voltage Conditioning	100 Hours	100 Hours	100 Hours	100 Hours	Para 3.6				10	100%	N/A		
Constant Acceleration	3,000g's, Y1 Direction	3,000g's, Y1 Direction	3,000g's, Y1 Direction	3,000g's, Y1 Direction	883 Meth. 2001				10				
<b>ENVIRONMENTAL TESTS, LEVEL II</b>													
Thermal Shock & Voltage Conditioning	20 cycles/168 hr. min.	20 cycles/168 hr. min.	20 cycles/168 hr. min.	20 cycles/168 hr. min.	Para 3.6 & 3.15						100%		
Destructive Physical Analysis Report					EIA-469						Included		
Voltage Temp. Limits	0 ± 30 ppm/°C	P90 ± 20 ppm/°C	0 ± 30 ppm/°C	+15, -25%	Para 3.14						12		
Life Test	1000 Hours Each Lot	1000 Hours Each Lot	1000 Hours Each Lot	1000 Hours Each Lot	Para 3.19						25 min.		
Humidity, Steady State, Low Voltage	240 Hours min.	240 Hours min.	240 Hours min.	240 Hours min.	Para 3.18						12		
RoHS Compliant, Yes/No	Specify	Specify	Specify	Specify									

\*FIT (Failure In Time) Calculations are based on assumed CONTINUOUS operating temperatures 85° C and 100° C

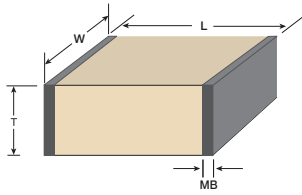

**Capacitance Codes for Multilayer Capacitor**

**First Two Digits** = Significant Figures of Capacitance in Picofarads  
**Third Digit** = Additional Number of Zeros  
**Example:**  
 100 = 10 pF  
 102 = 1,000 pF  
 104 = 100,000 pF

**Capacitance Tolerance Codes**

Code	Tolerance	Cap Range	Dielectrics
A	± .05 pF	< 2.2 pF	U, V, N
B	± .1 pF	< 10 pF	U, V, N
C	± .25 pF	< 10 pF	U, V, N
D	± .5 pF	< 10 pF	U, V, N
F	± 1%	≥ 10 pF	U, V, N
G	± 2%	≥ 10 pF	U, V, N
J	± 5%	≥ 10 pF	U, V, N
K	± 10%	≥ 10 pF	all
M	± 20%	≥ 10 pF	all

**Termination Codes**

Code	RoHS Comp.	Typical Application	Termination Build up	Recommended Reflow Temp.
T	Yes	Solder Reflow	100% Tin Plated Nickel Barrier Silver Base	220°C to 260°C Typical*
N	No	Solder Reflow	90% Tin/10% Lead Plated Nickel Barrier Silver Base	220°C to 260°C Typical*
P	Yes	Conductive Epoxy Non-Magnetic	Palladium-Silver	Cure Epoxy as per Manufacturer's Spec.
G	Yes	Conductive Epoxy, Wire Bondable	50 μ" Gold Typical Nickel Barrier Silver Base	Cure Epoxy as per Manufacturer's Spec.

**Working Voltage**

Code	WVDC
2	50
3	100
A	150
4	200
5	300
6	500

**Packaging Codes**

1 = Tape and Reel  
 5 = Waffle Pack

**RoHS**

Code	Compliant
N	No
R	Yes, ends Dec. 2012
C	Yes, starts Jan. 2013



# SELECTION TABLE: VERTICAL ELECTRODE™ CAPACITORS – SURFACE MOUNT

SIZE CODE	W inch (mm)	L inch (mm)	T inch (mm)	MB max. inch (mm)	Working Voltage (WVDC) Max.	Capacitance (pF)	INDUSTRIAL Test Code M				MILITARY/SPACE Test Code N				S2P Files Dielectric Codes				Performance Curves Dielectric Codes				
							NPO Porcelain Code U (pF)	P90 Porcelain Code V (pF)	NPO Ceramic Code N (pF)	BX Ceramic Code B (pF)	NPO Porcelain Code U (pF)	P90 Porcelain Code V (pF)	NPO Ceramic Code N (pF)	BX Ceramic Code B (pF)	U	V	N	B	U	V	N	B	
0505	0.055 (1.397) ± 0.015 (0.381)	0.055 (1.397) ± 0.015 (0.381)	0.040 (1.397) ± 0.015 (0.381)	0.020 (0.508)	200	Min:	0.1	0.1															
					200	Max:	100	100															
					150	Min:	0.1	0.1	110		0.1	0.1											
					150	Max:	100	100	620		100	100											
					50	Min:			110	1,000	0.1	0.1	110	1,000									
					50	Max:			1,000	10,000	100	100	1,000	10,000									
1010	0.110 (2.794) ± 0.015 (0.381)	0.110 +0.020 -0.010 (2.794 +0.508 -0.254)	0.087 (2.210) ± 0.015 (0.381)		500	Min:	0.1	0.1			0.1	0.1											
					500	Max:	100	100			100	100											
					300	Min:	110	110			110	110											
					300	Max:	200	200			200	200											
					200	Min:	220	220			220	220											
					200	Max:	470	470			470	470											
					100	Min:	510	510			510	510											
					100	Max:	620	620			620	620											
					50	Min:	680	680	1,200	5,000	680	680	1,200	5,000									
					50	Max:	1000	1000	5,100	100,000	1,000	1,000	5,100	100,000									

● = Web Link

## PART NUMBER ASSEMBLY FOR ENGINEERING KITS

Steps to Create Your Custom Kit  
Example: M VP 0505 U KIT00 T

Step #1	M = Select Test Codes M or N (See Page 4)	Step #4	U = Select Dielectric Material Code (See Selection Table Above)
Step #2	VP = Product Code	Step #5	KIT00 = Select Kit Number (See Page 4 and Kit Numbers Below)
Step #3	0505 = Select Case Size Code (See Selection Table Above)	Step #6	T = Termination Code (See Termination Codes Page 4)

Kit Number	Cap. Value Range	Different Values	Min. Pieces per Value	pF	Cap. Tol. Code	Kit Price
KIT00	0.3 - 100	27	15	0.1, 0.2, 0.3, 0.4, 0.5, 0.6, 0.7, 0.8, 0.9, 1.0, 1.2, 1.5, 1.8, 2.2, 2.7, 3.3, 3.9, 4.7, 5.6, 6.8, 8.2, 10, 12, 15, 18, 22, 27, 33, 39, 47, 56, 68, 82, 100	B, J, K	\$260.00
KIT01	0.1 - 1.0	12	15	0.1, 0.2, 0.3, 0.4, 0.5, 0.6, 0.7, 0.8, 0.9, 1.0, 1.1, 1.2	A	\$120.00
KIT10	0.3 - 3.6	12	15	0.3, 0.5, 0.7, 1.0, 1.2, 1.5, 1.8, 2.0, 2.2, 2.4, 2.7, 3.0,	B & J	\$120.00
KIT20	3.6 - 20	14	15	3.3, 3.6, 3.9, 4.3, 4.7, 5.1, 5.6, 6.2, 6.8, 10, 12, 15, 18, 20	B & J	\$140.00
KIT30	22 - 100	16	15	22, 24, 27, 30, 33, 36, 39, 43, 47, 51, 56, 62, 68, 75, 82, 100	J & K	\$160.00
KIT40	120 - 1000	12	15	120, 150, 180, 220, 270, 330, 390, 470, 560, 680, 820, 1000	K & M	\$120.00
KIT50	1,000-10,000	7	15	1000, 1500, 2200, 3300, 4700, 6800, 10000	K & M	\$100.00
KIT60	5,000-100,000	7	15	10000, 15000, 22000, 33000, 47000, 68000, 100000	K & M	\$100.00
KIT99				Contact factory for custom kit		



PRESIDIO COMPONENTS, INC.

7169 Construction Court, San Diego, CA 92121 • Tel: 858-578-9390 • Fax: 800-538-3880 or 858-578-6225  
www.presidiocomponents.com • info@presidiocomponents.com

# TEMPERATURE STABLE (NPO) ULTRA-PORCELAIN™ CERAMIC CAPACITORS FOR HIGH RF POWER APPLICATIONS

## PORCELAIN NPO

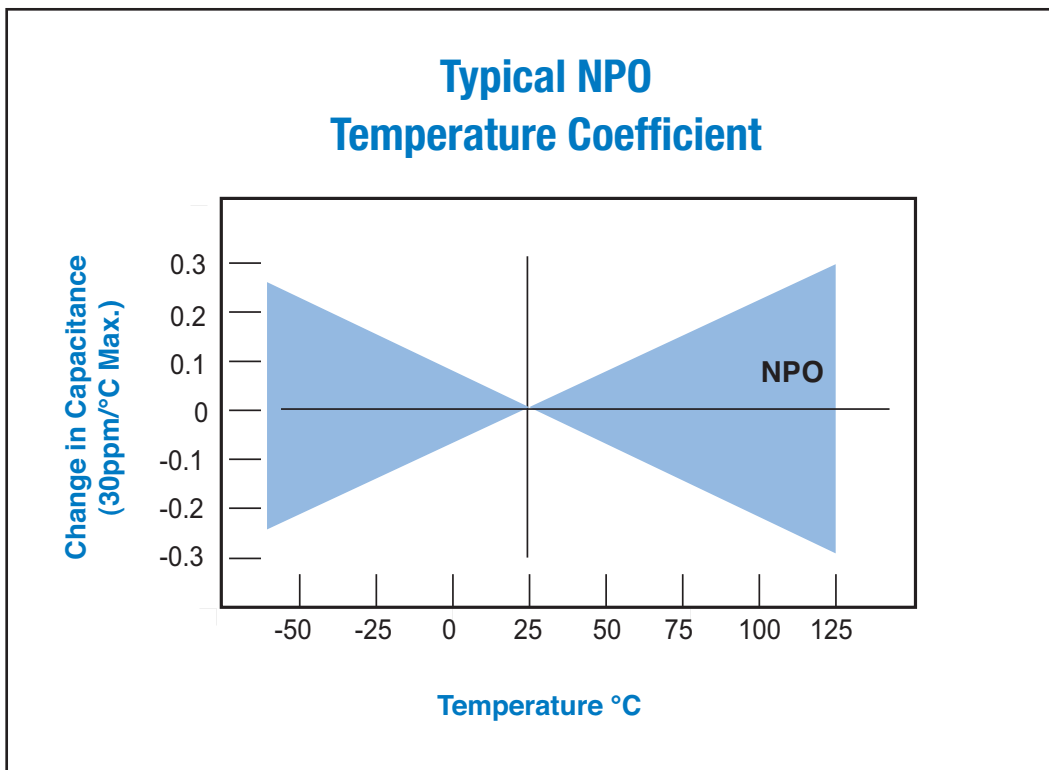
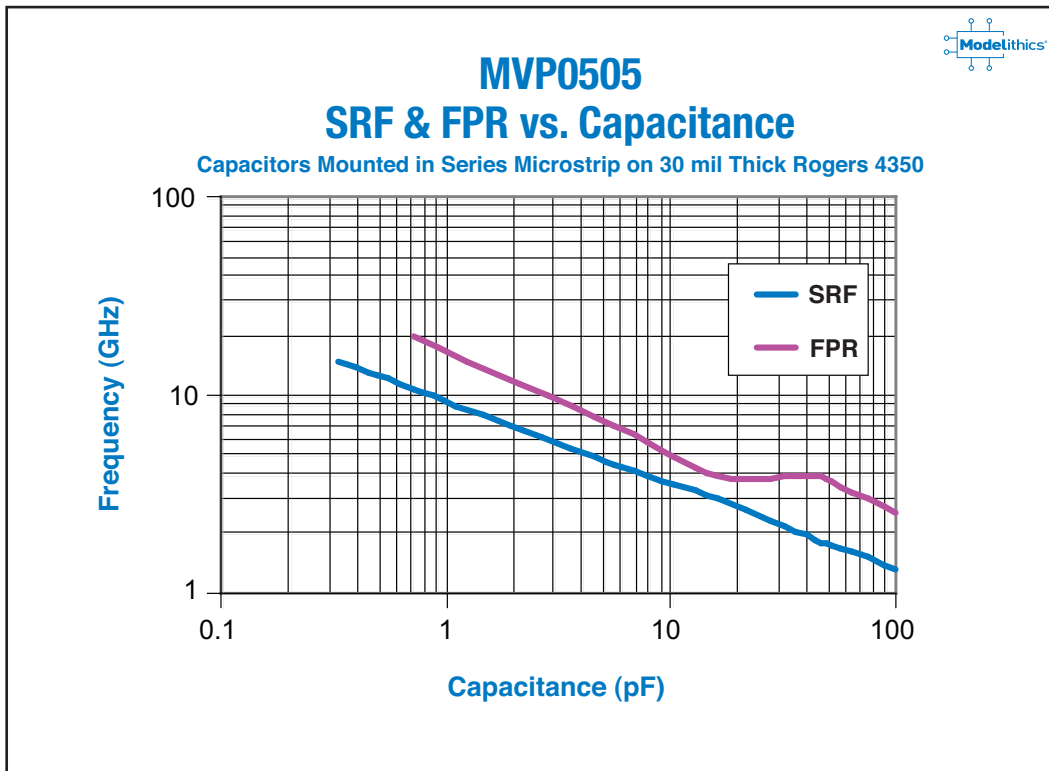

# TEMPERATURE STABLE (NPO) ULTRA-PORCELAIN™ CERAMIC CAPACITORS FOR HIGH RF POWER APPLICATIONS

## PORCELAIN NPO

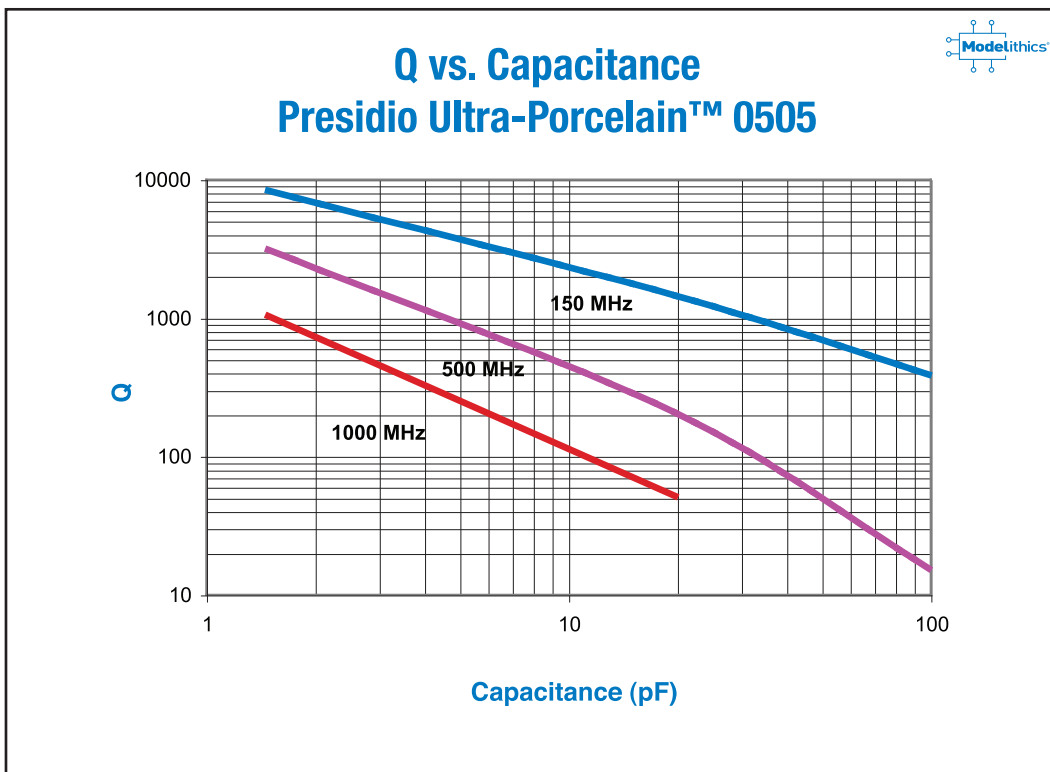
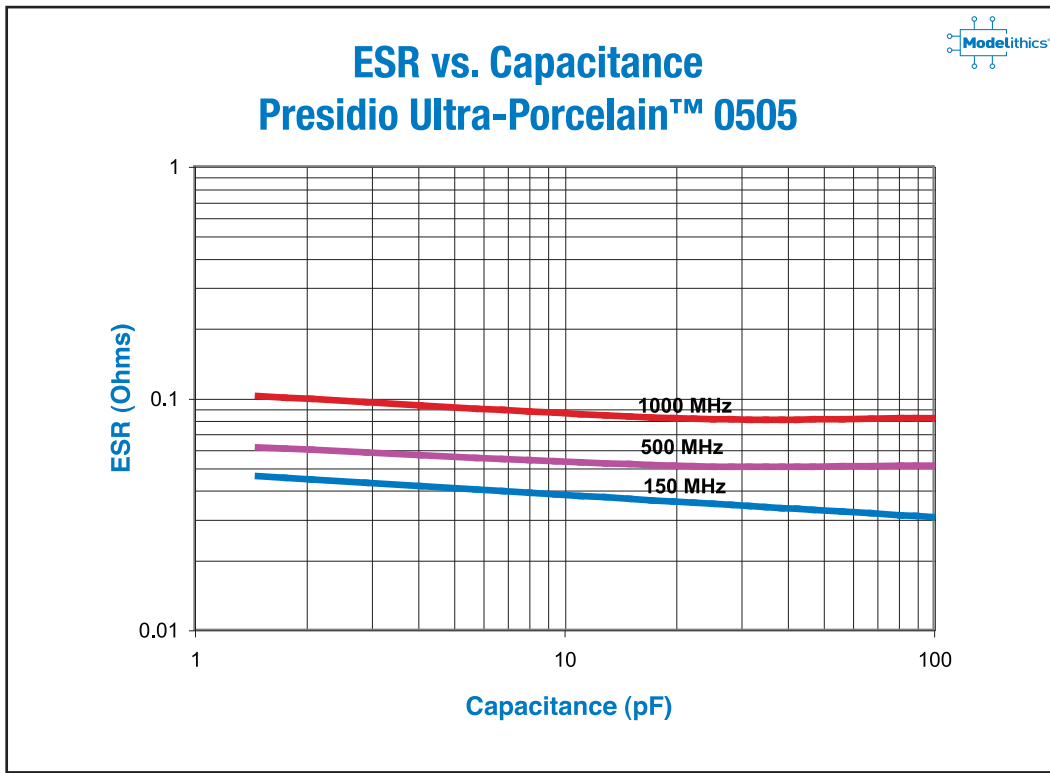

 PRESIDIO COMPONENTS, INC.

7169 Construction Court, San Diego, CA 92121 • Tel: 858-578-9390 • Fax: 800-538-3880 or 858-578-6225  
www.presidiocomponents.com • info@presidiocomponents.com

TEMPERATURE STABLE (NPO) ULTRA-PORCELAIN™ CERAMIC CAPACITORS

# TEMPERATURE STABLE (P90) ULTRA-PORCELAIN™ CERAMIC CAPACITORS FOR HIGH RF POWER APPLICATIONS

TEMPERATURE STABLE (P90) ULTRA-PORCELAIN™ CERAMIC CAPACITORS

## PORCELAIN P90

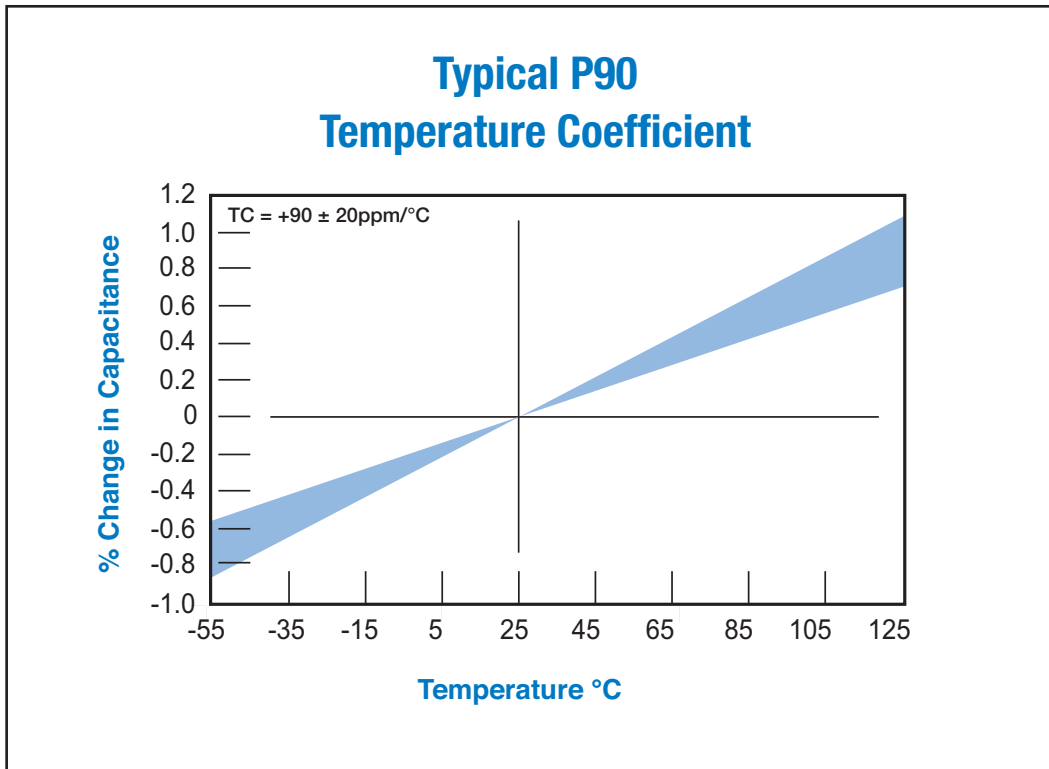
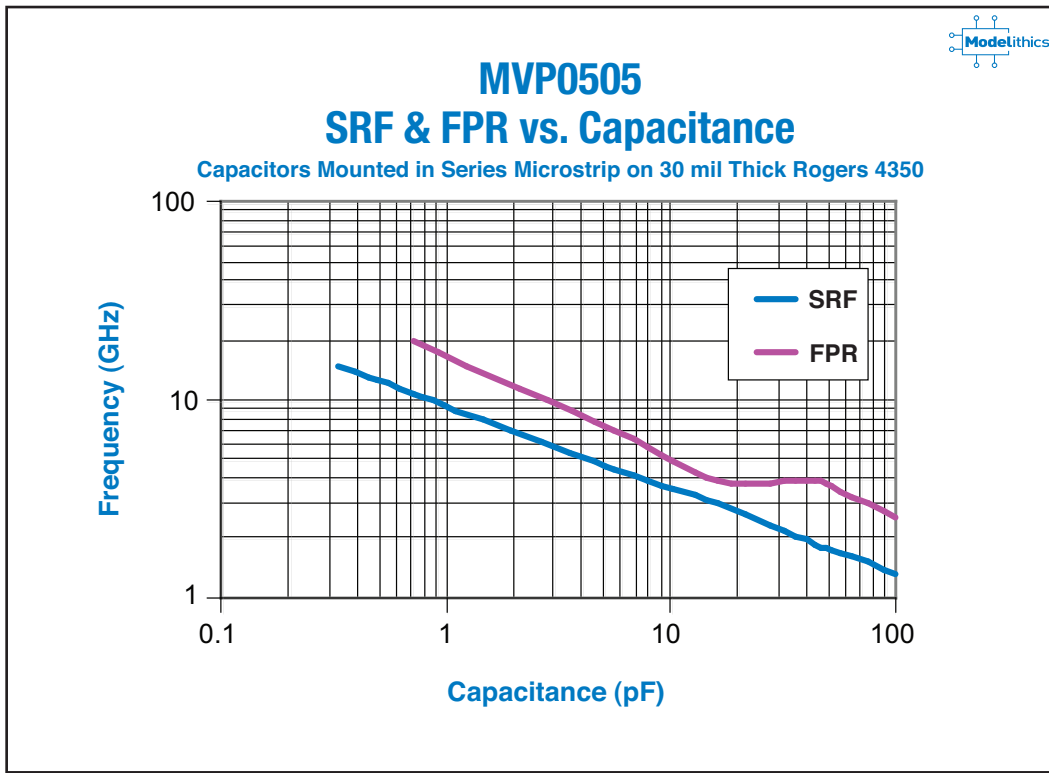

 PRESIDIO COMPONENTS, INC.

7169 Construction Court, San Diego, CA 92121 • Tel: 858-578-9390 • Fax: 800-538-3880 or 858-578-6225  
[www.presidiocomponents.com](http://www.presidiocomponents.com) • [info@presidiocomponents.com](mailto:info@presidiocomponents.com)

# TEMPERATURE STABLE (P90) ULTRA-PORCELAIN™ CERAMIC CAPACITORS FOR HIGH RF POWER APPLICATIONS

## PORCELAIN P90

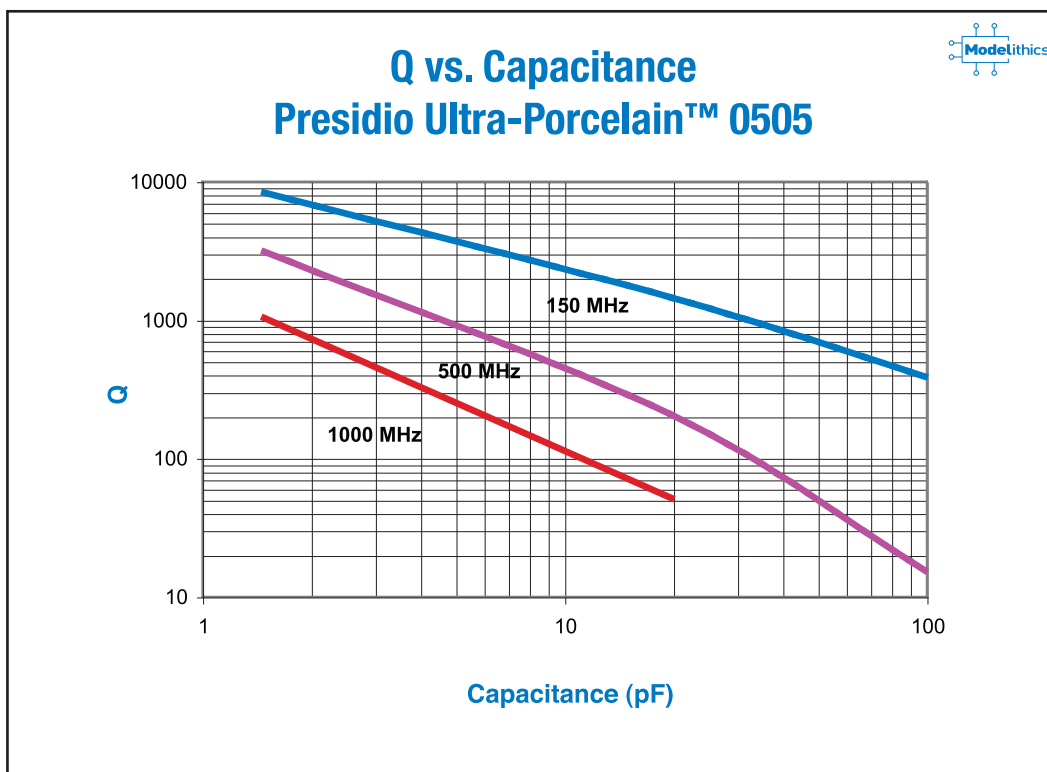
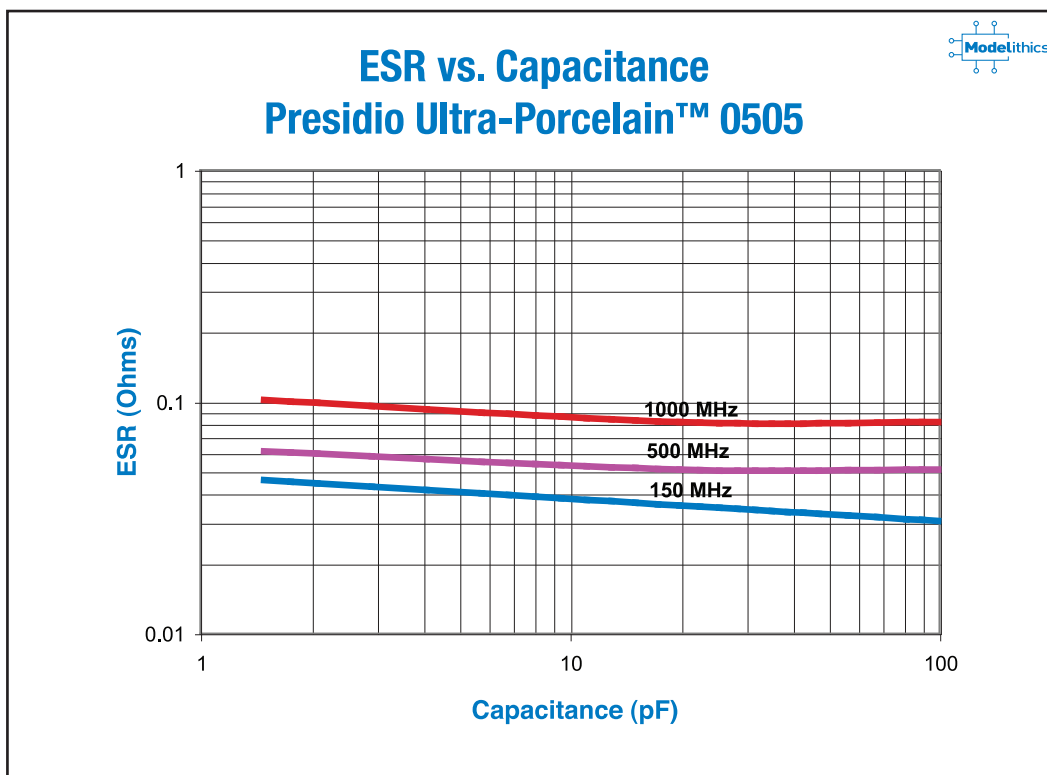

 PRESIDIO COMPONENTS, INC.

7169 Construction Court, San Diego, CA 92121 • Tel: 858-578-9390 • Fax: 800-538-3880 or 858-578-6225  
www.presidiocomponents.com • info@presidiocomponents.com

# TEMPERATURE STABLE (NPO & BX) CERAMIC CAPACITORS FOR HIGH RF POWER APPLICATIONS

## CERAMIC NPO AND BX

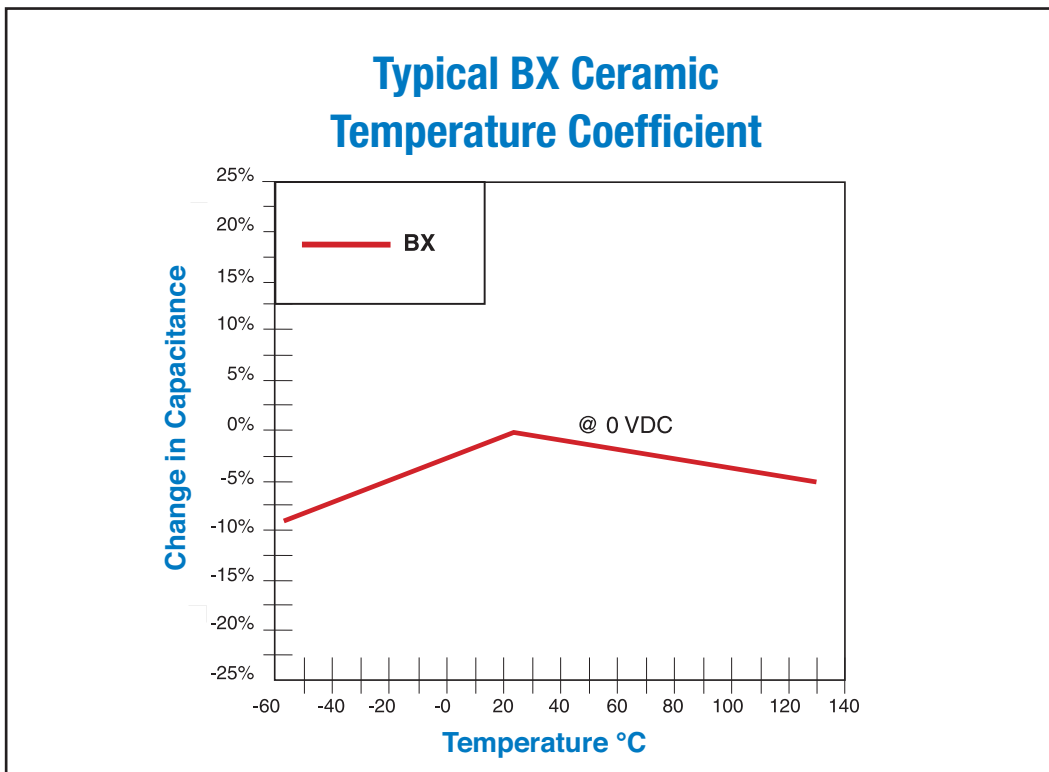
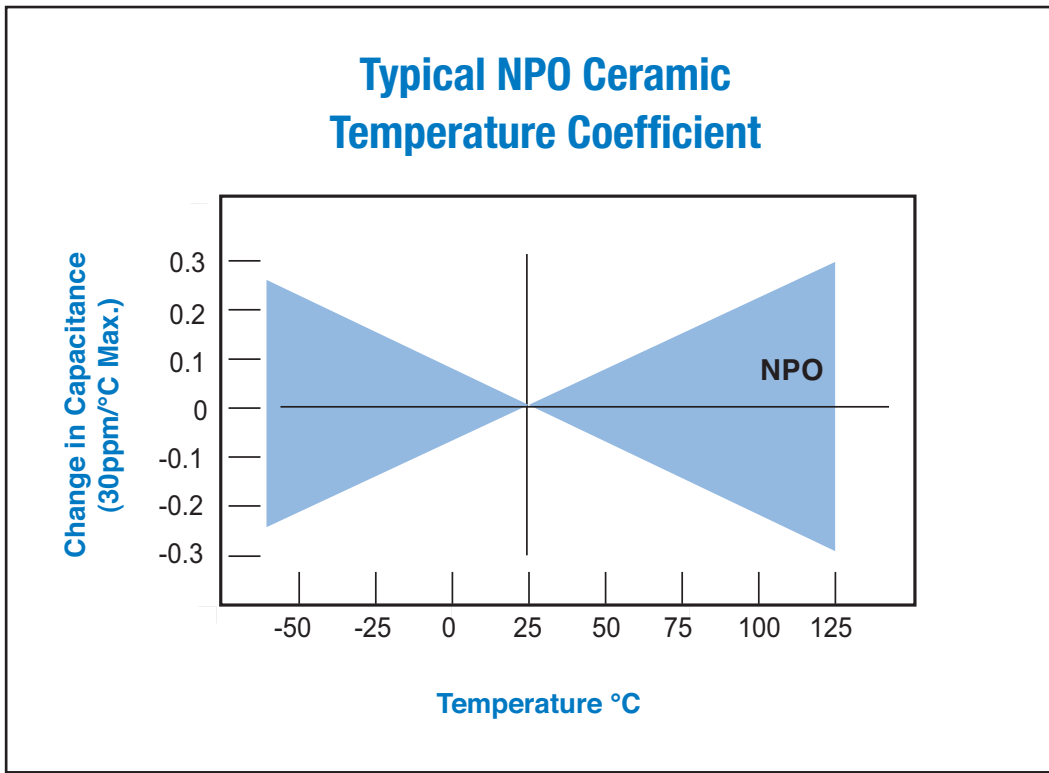

# FREE MODEL DOWNLOAD

## SURFACE MOUNT CHIP CAPACITOR MODEL

### MODEL FEATURES:

- Substrate scalable
- Broadband (DC to 20 GHz)
- Equivalent circuit topology
- Accurate effective series resistance
- 21 capacitor values (0.33 to 250 pF)
- Developed for microstrip interconnects

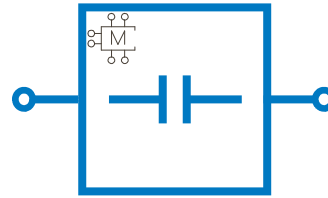

**CAP-PRS-0505-001**  
**0.33 to 250 pF**  
**0505 Body Style**

### MODEL DESCRIPTION

The CAP-PRS-0505-001 family are substrate scalable models for 0505 surface mount chip capacitors from Presidio. The models are for use with microstrip applications and account for substrate (or printed circuit board) related parasitic effects. Substrate height, dielectric constant, loss tangent, interconnect metal thickness and component tolerance are model input parameters. Models account for up to two higher-order resonant frequency pairs beyond the fundamental series resonant frequency. Accurate effective series resistance (ESR) is modeled over the frequency range. A single substrate scalable Global Model™ is available that accurately emulates all capacitor values within the valid capacitance range.

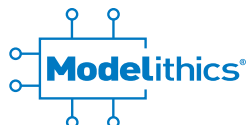
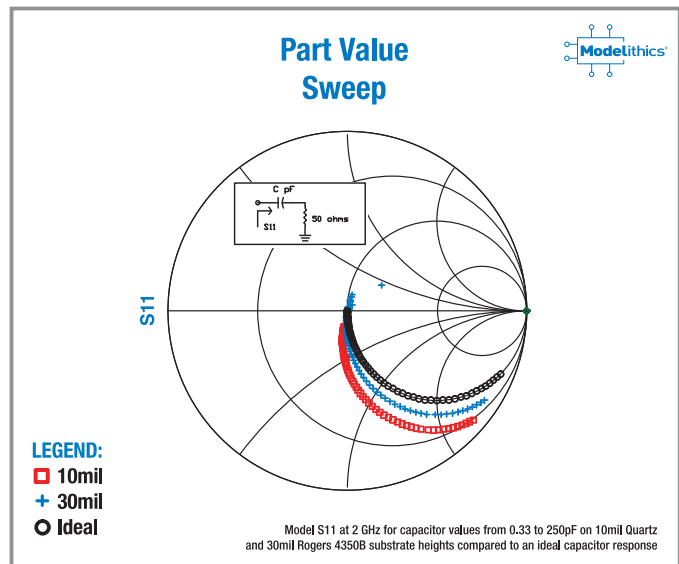
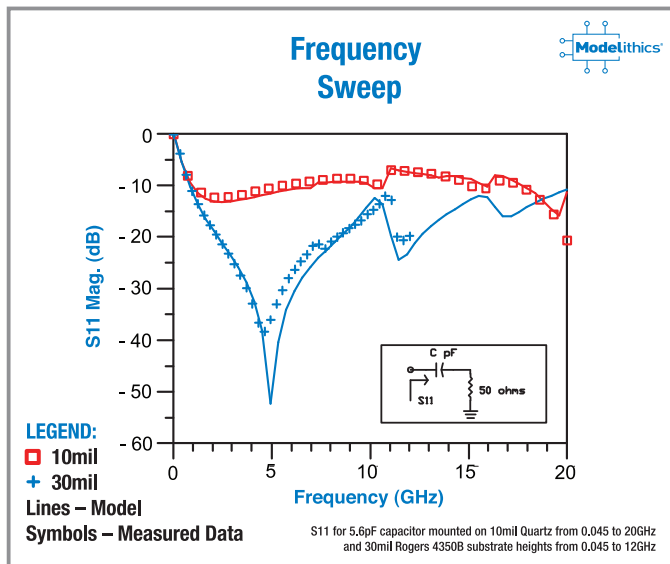

<http://www.modelithics.com/mvp/Presidio>

 **PRESIDIO COMPONENTS, INC.**

7169 Construction Court, San Diego, CA 92121 • Tel: 858-578-9390 • Fax: 800-538-3880 or 858-578-6225  
[www.presidiocomponents.com](http://www.presidiocomponents.com) • [info@presidiocomponents.com](mailto:info@presidiocomponents.com)

# FREE MODEL DOWNLOAD

## Technical Notes

- Two-port S-parameters are measured using a vector network analyzer and on-board probing with calibration referenced to the outside edges of the component pad stack.
- Capacitors are measured in a series microstrip configuration. Models for alternative interconnect configurations (e.g. coplanar waveguide) can be ordered through Modelithics custom services.
- ESR is measured using a 34A Boonton coaxial resonator line.
- Substrates used to extract the models: 10 mil Quartz, 30 mil Rogers 4350B
- Typical range of valid substrate types (substrate height H in mils and dielectric constant Er):  $2.6 \leq H/Er \leq 8.1$ .
- Additional information about Presidio capacitors is available at [www.presidiocomponents.com](http://www.presidiocomponents.com)

## Capacitor Values (pF)

0.33	6.8	56	180
0.68	8.2	82	200
1	16	100	250
1.5	18	120	
4.7	43	140	
5.6	47	160	

All capacitor values represent measurement-based models.

## PC Board Footprint

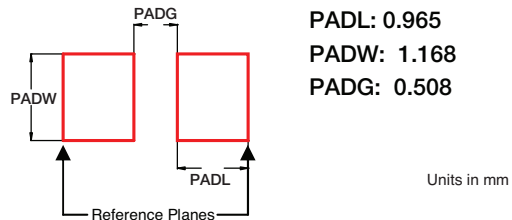

## Typical Measured Series 2-port S-Parameter Data Versus Simulated Data

### 10 Mil Substrate

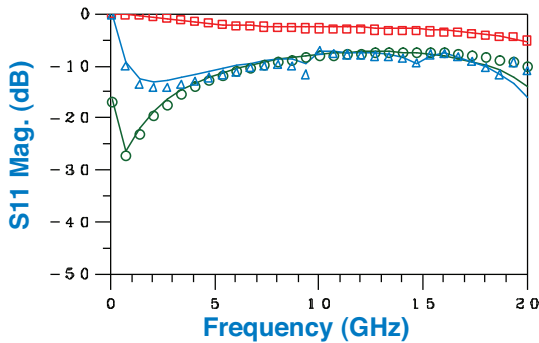

### 10 Mil Substrate

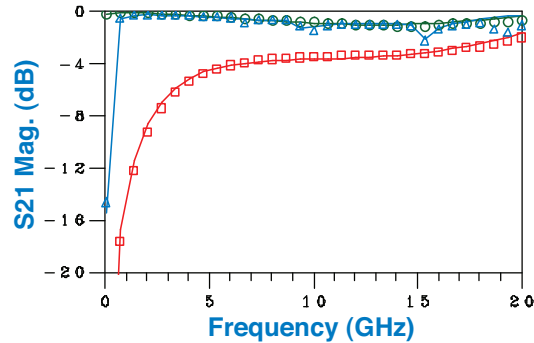

### 30 Mil Substrate

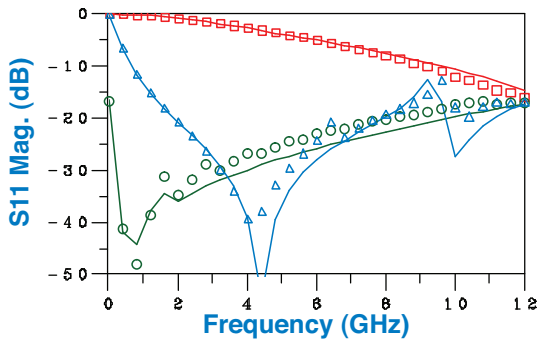

### 30 Mil Substrate

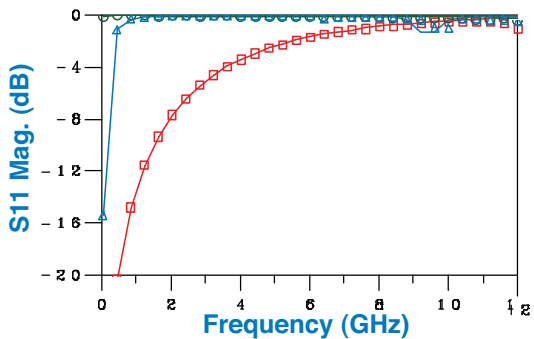

Legend: □ 0.33pF, △ 6.8pF, ○ 250pF, Solid line = Model data, Symbol = Measured data

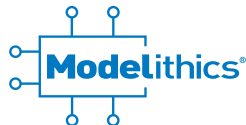

<http://www.modelithics.com/mvp/Presidio>



PRESIDIO COMPONENTS, INC.

7169 Construction Court, San Diego, CA 92121 • Tel: 858-578-9390 • Fax: 800-538-3880 or 858-578-6225  
[www.presidiocomponents.com](http://www.presidiocomponents.com) • [info@presidiocomponents.com](mailto:info@presidiocomponents.com)

## Effective Capacitance Data

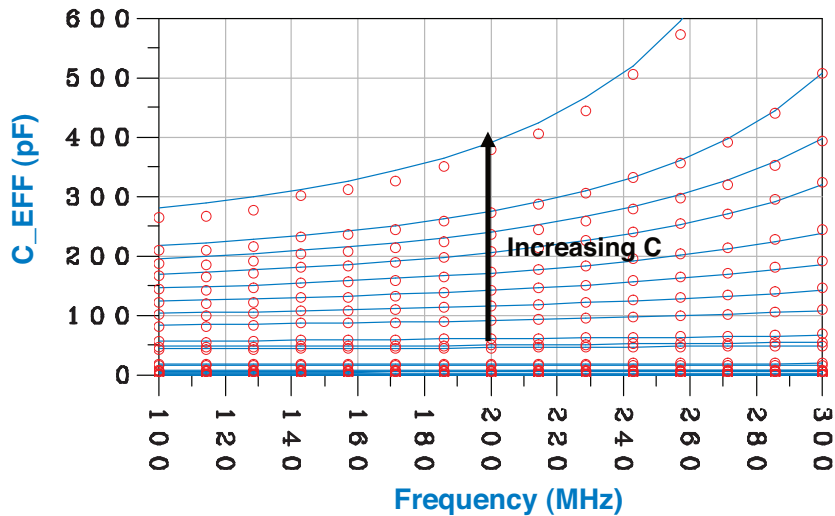

Legend: **Blue** solid lines – Model response on 30mil Rogers 4350B substrate for capacitance sweep  
**Red** circles – Measurement data on 30mil Rogers 4350B substrate for capacitance sweep

## Simulated Q-Factor

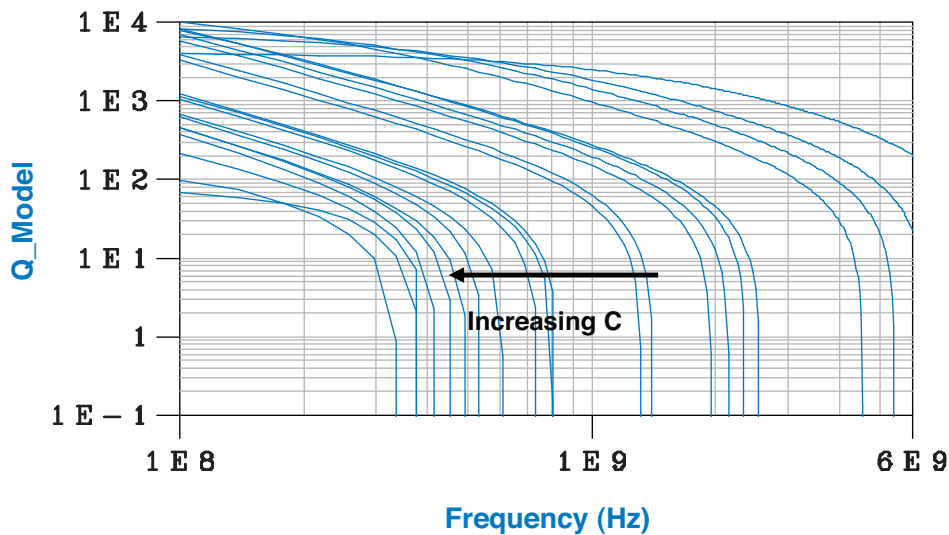

Legend: **Blue** solid lines – Model response on 30mil Rogers 4350B substrate

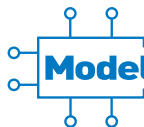

Modelithics®

<http://www.modelithics.com/mvp/Presidio>



PRESIDIO COMPONENTS, INC.

7169 Construction Court, San Diego, CA 92121 • Tel: 858-578-9390 • Fax: 800-538-3880 or 858-578-6225  
[www.presidiocomponents.com](http://www.presidiocomponents.com) • [info@presidiocomponents.com](mailto:info@presidiocomponents.com)

# CUSTOM PRODUCTS

## PRESIDIO COMPONENTS, INC.

Presidio maintains more than 70 million standard commercial and military parts in inventory. If you need a custom product, call our engineering team.

Custom products include non-standard part sizes and voltages such as high voltage, high temperature, high "Q", custom leads, cryogenic ceramics, negative and positive temperature characteristic ceramics, and piezoelectric formulations. European sizes are also available.

Backed with numerous patents and hundreds of years of combined experience, Presidio's engineering team is ready and able to create the ideal solution for any application.

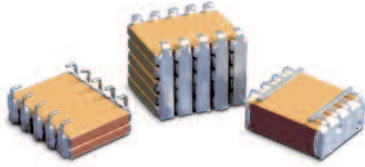

CUSTOM LEADS



'S' LEADS



CUSTOM STACKED  
CUSTOM ASSEMBLY

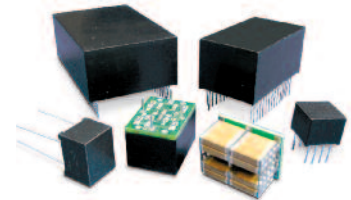

ENCAPSULATED



HIGH TEMP  
DOWNHOLE OIL

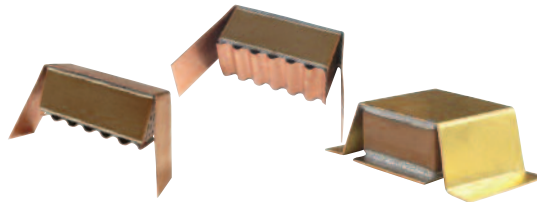

POWER-STACK™ CAPACITORS



HIGH FREQUENCY  
HIGH POWER





# MAIN PRODUCT CATALOGS

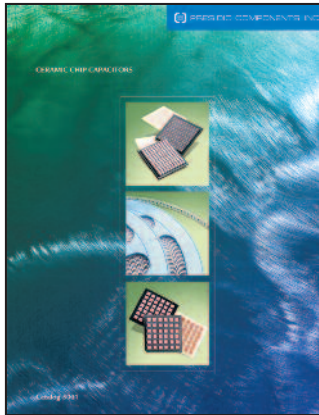

**CERAMIC CHIP CAPACITORS**



**HIGH RELIABILITY EXTENDED RANGE CHIPS FOR SPACE**

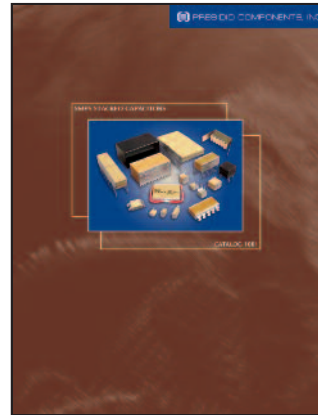

**SMPS STACKED CAPACITORS**

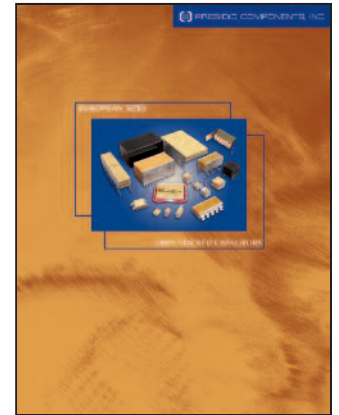

**EUROPEAN SIZES SMPS STACKED CAPACITORS**

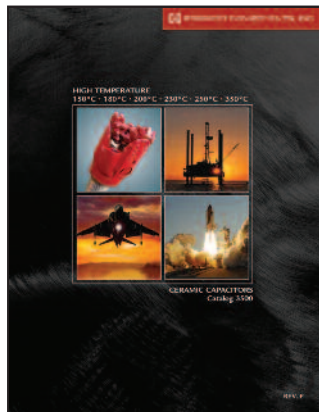

**HIGH TEMPERATURE CERAMIC CAPACITORS**

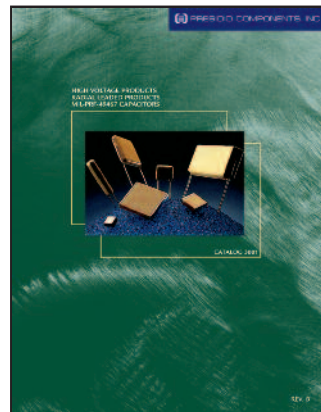

**HIGH VOLTAGE & RADIAL LEADED PRODUCTS MIL-PRF-49467 CAPACITORS**

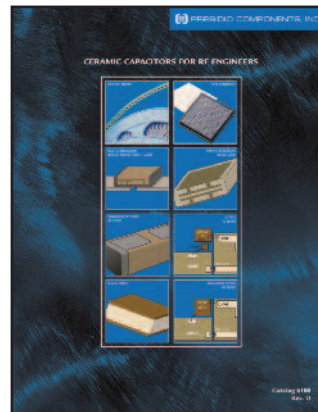

**CERAMIC CAPACITORS FOR RF, MICROWAVE & FIBER OPTIC APPLICATIONS**



**ULTRA-PORCELAIN RF CAPACITORS**